

## B511 - DPF Differential Pressure Sensor for Engine F5D (DOC/DPF) (5GL), Component Information

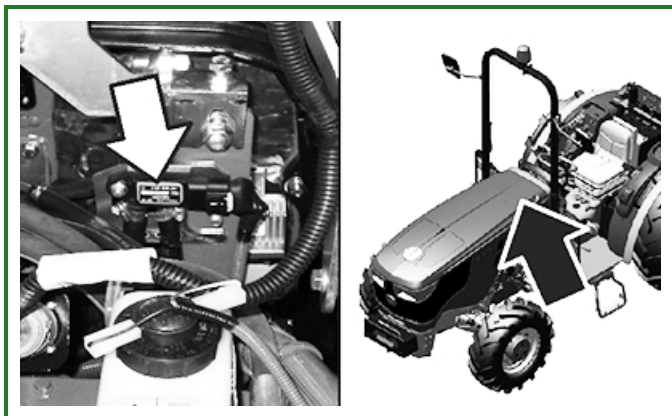

PY37434-UN: B511 - OOS

-: Component information

| B511<br>Component information |   |
|-------------------------------|---|
| <b>Tractor Model:</b>         | 5GL   |
| <b>Connector:</b>             | P2  |
| <b>Diagnostic Schematic:</b>  | SE91, See <a href="#">50FA - Electronic Engine Control (5GL)</a> , <a href="#">Summary of References</a> in section 240B, Group 50FA. |

## B511 - DPF Differential Pressure Sensor for Engine F5D (DOC/DPF), Connector Information

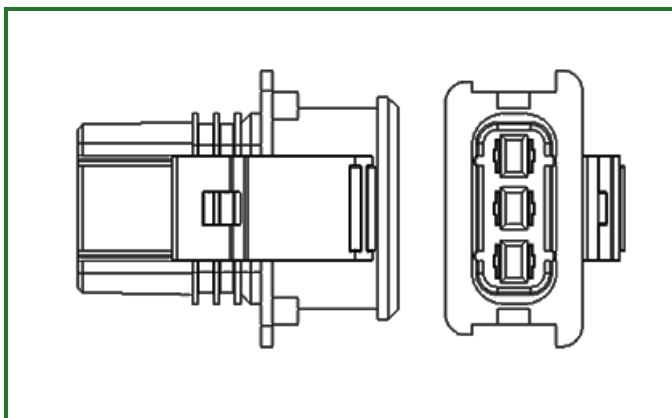

PY37435-UN: P2

-: Connector information

| P2<br>Connector information |      |
|-----------------------------|------|
| <b>Number of pins:</b>      | 3    |
| <b>Connection point:</b>    | B511 |

| P2<br>Connector information |   |
|-----------------------------|---|
| <b>Wiring harness:</b>      | W02, See <a href="#">Summary of References of Electrical Components, Wiring Harnesses (5GL)</a> in Section 249B, Group 40W. |

## -: Connector layout

| P2<br>Connector layout |           |                  |
|------------------------|-----------|------------------|
| Pin                    | Wire Code | Wire Color       |
| 1                      | C-N       | Orange and Black |
| 2                      | R-G       | Pink and Yellow  |
| 3                      | M-V       | Brown and Green  |

Go to [Section\\_249B:Group\\_40B](#)

SD74272,000099D-19-20170524