

Section 4-6: Miscellaneous—Specifications

328E Machine Dimensions

328E Machine Specifications

332E Machine Dimensions

332E Machine Specifications

328E Drain and Refill Capacities

332E Drain and Refill Capacities

Rated Operating Capacity

Pallet Fork Lift Chart

328E Machine Dimensions

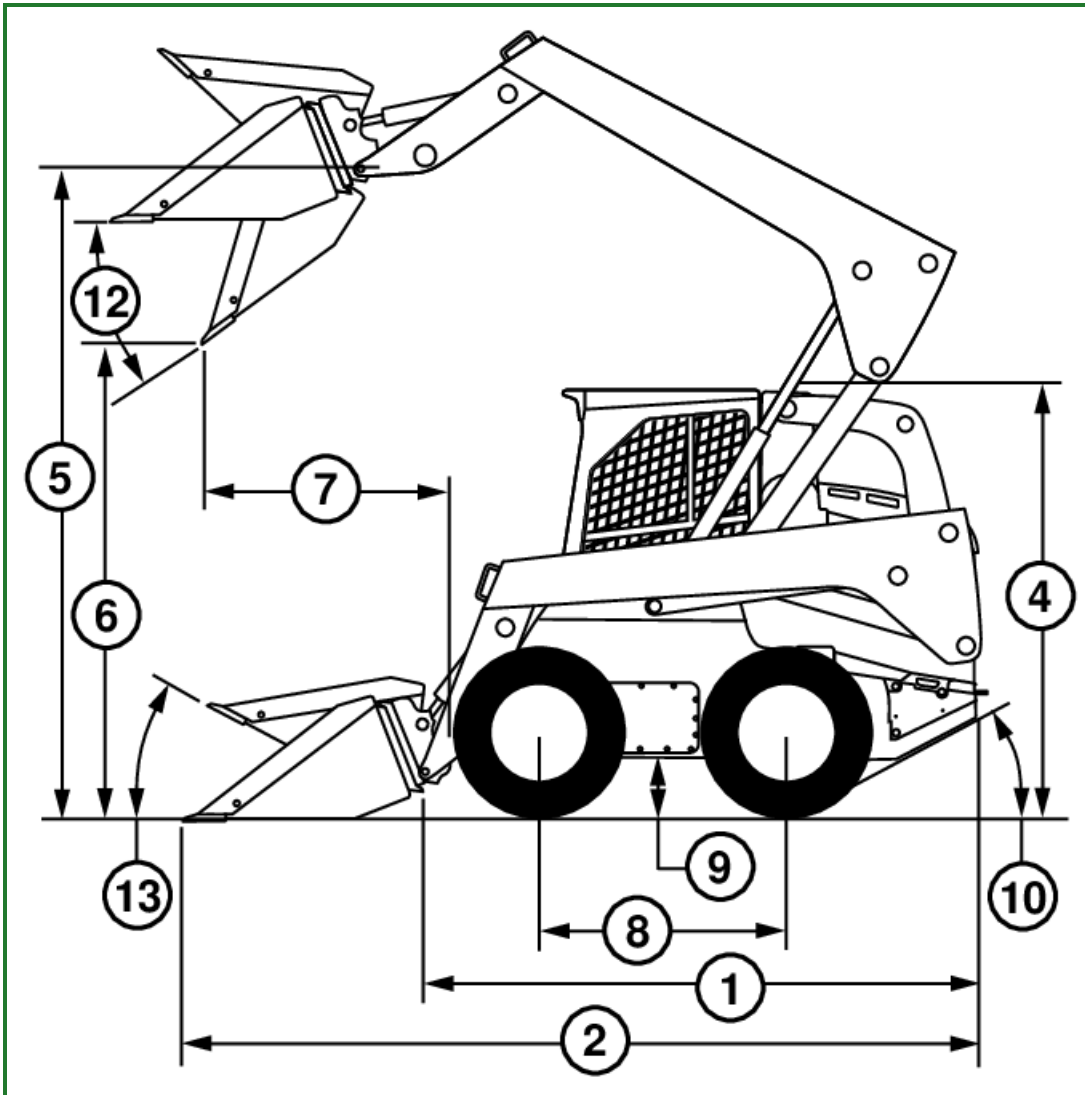

TX1065132-UN: Machine Dimensions-Side View

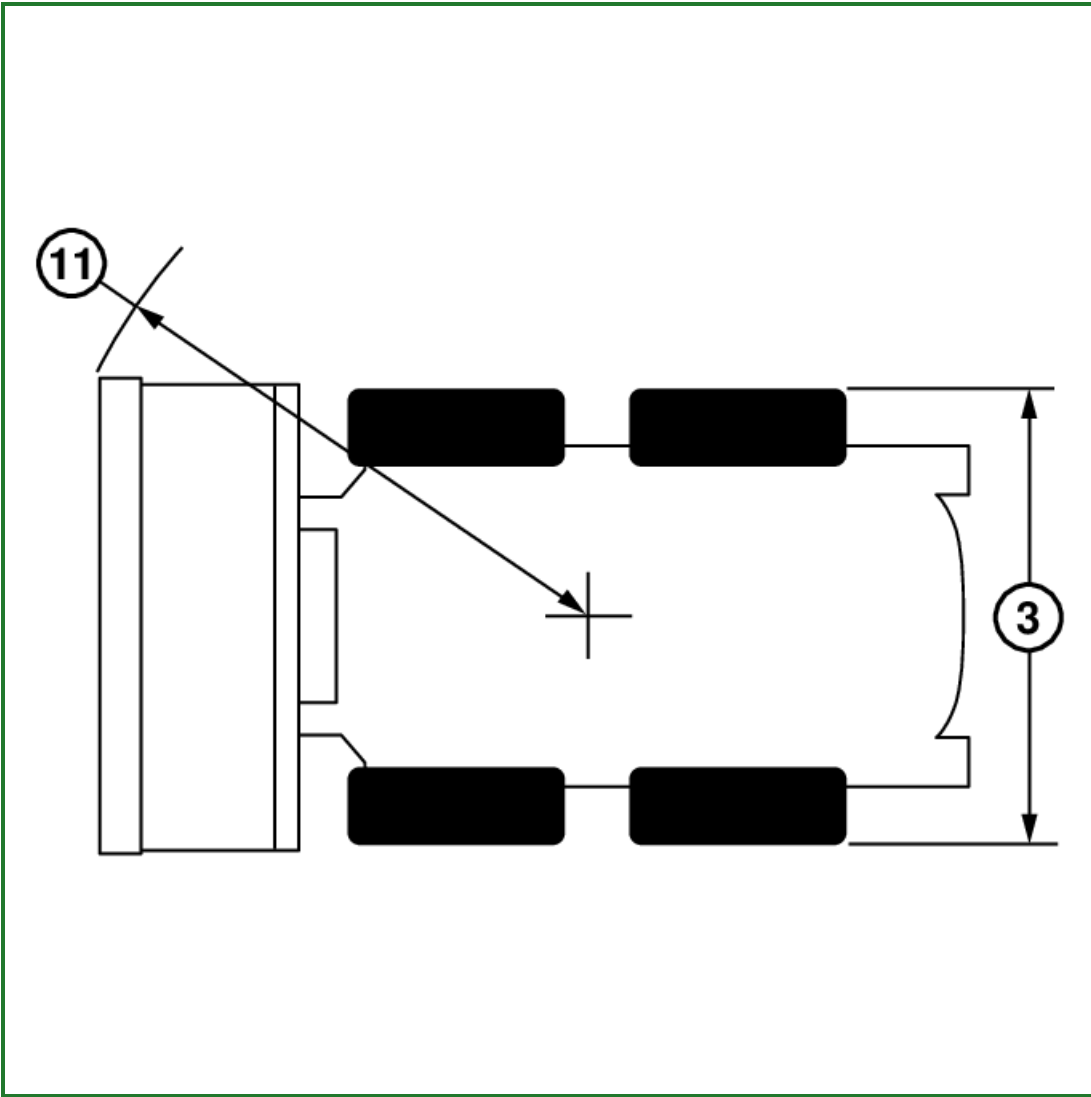

TX1065133-UN: Machine Dimensions-Top View

NOTE:

Specifications and design subject to change without notice. Wherever applicable, specifications are in accordance with ISO and SAE standards. Except where otherwise noted, these specifications are based on a machine equipped with standard tires and bucket.

Item	Measurement	Specification
1—Overall Length (less bucket)	Length	3.05 m 10 ft. 0 in.
2—Overall Length (with foundry bucket)	Length	3.66 m 12 ft. 0 in.
2—Overall Length (with construction bucket)	Length	3.93 m 12 ft. 11 in.
3—Overall Width (less bucket)	Width	1.95 m 6 ft. 5 in.
4—Height to Top of ROPS	Height	2.15 m 7 ft. 1 in.
5—Height to Hinge Pin	Height	3.22 m 10 ft. 7 in.
6—Dump Height (with foundry bucket)	Height	2.57 m 8 ft. 5 in.
6—Dump Height (with construction bucket)	Height	2.36 m 7 ft. 9 in.
7—Dump Reach (with foundry bucket)	Reach	0.80 m 2 ft. 7 in.
7—Dump Reach (with construction bucket)	Reach	0.98 m 3 ft. 3 in.
8—Wheel Base	Distance	1.23 m 4 ft. 0 in.
9—Ground Clearance	Height	0.29 m 1 ft. 0 in.
10—Angle of Departure	Angle	29°
11—Front Turn Radius (with foundry bucket)	Distance	2.17 m 7 ft. 1 in.
12—Dump Angle (full lift height)	Angle	45°
13—Bucket Rollback (ground level)	Angle	35°
Base Machine	Operating Weight	3982 kg 8770 lb.

JK47244,0000194-19-20121226

328E Machine Specifications

Item	Measurement	Specification
Yanmar 4TNV94CHT	Non-Road Emission Standards	Certified To EPA Interim Tier 4 Emissions
	Type	4-Stroke Cycle, Turbocharged, Intercooled
	Bore and Stroke	94 x 110 mm 3.7 x 4.33 in.
	Cylinders	4
	Displacement	3.1 L 186.3 cu in.
	Peak Net Horsepower @ 2500 rpm	62.0 kw 83.1 hp
	Cooling Fan	Hydraulic Variable Speed
	Electrical System	12 Volt
	Battery	150 Minutes Reserve Capacity

JK47244,0000195-19-20130108