

Differential Lock Operation

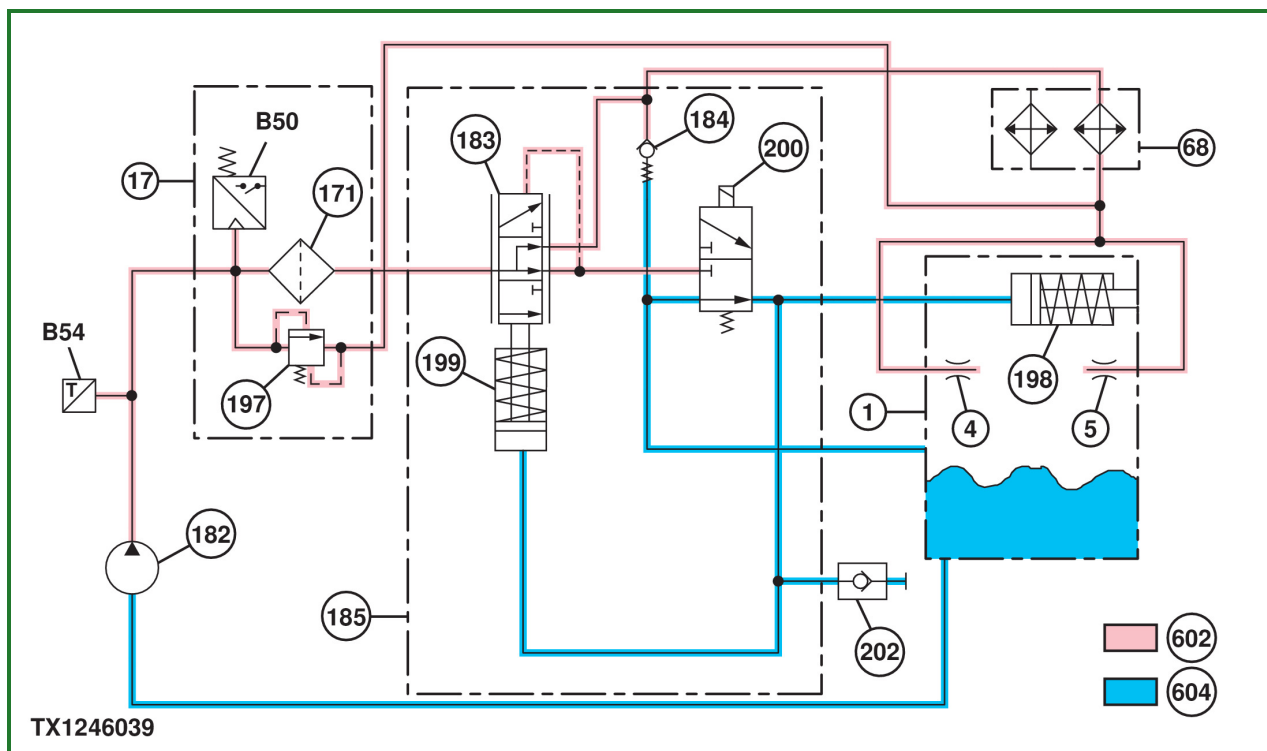

TX1246039-UN: Differential Lock Circuit Schematic

LEGEND:

- 1 - Differential Housing
- 4 - Right Service Brake Cooling Port
- 5 - Left Service Brake Cooling Port
- 17 - Axle Oil Filter Manifold
- 68 - Hydraulic and Differential Oil Cooler
- 171 - Axle Oil Filter
- 182 - Differential Lock Pump
- 183 - Differential Lock Pressure Regulating Valve
- 184 - Differential Oil Cooler Bypass Valve
- 185 - Differential Lock Valve
- 197 - Axle Oil Filter Bypass Valve
- 198 - Differential Lock Clutch Piston
- 199 - Differential Lock Pressure Regulating Valve Piston
- 200 - Differential Lock Solenoid Valve
- 202 - Differential Lock Diagnostic Test Port
- 602 - Low-Pressure Oil
- 604 - Return Oil
- B50 - Axle Oil Filter Restriction Switch
- B54 - Axle Temperature Sensor

Actuating the differential lock locks up the bevel pinions in the axle and prevents differential action.

The differential lock pump (182) routes oil from the differential housing (1) through the axle oil filter (171) to the differential lock valve (185). The axle oil filter bypass valve (197) routes unfiltered oil to the differential housing brake cooling ports (4 and 5) and the hydraulic and differential oil cooler (68) if the axle oil filter becomes plugged. The differential oil cooler bypass valve (184) protects the cooler from being over pressurized. If the cooler becomes plugged, it sends oil to the differential housing. The differential lock pressure regulating valve (183) controls system circuit pressure for normal operation of the differential lock system. The differential lock circuit

always sends a portion of return oil (604) to the differential housing via two cooling ports to help cool the brakes. Differential lock diagnostic test port (202) is used for diagnostic and test procedures to check the differential lock solenoid operation for system pressure when the differential lock switch is in the ON position only. For component location, see [Power Train Component Location](#) . (Group 9020-15.)

When the differential lock switch is in the OFF position, oil is routed through the differential lock pressure regulating valve to the hydraulic and differential oil cooler, where the oil is cooled and then routed to two differential housing ports. The cooled oil sprays onto the brakes for cooling and then drips to the bottom of the differential housing for sump oil. There is no oil pressure against the differential lock clutch piston or disc clutch. This allows the bevel pinions to move freely and allows the left and right axles to turn at different speeds. Some oil passing through the differential lock pressure regulating valve is routed to the end of the valve to help the valve maintain its position.

When the differential lock switch is in the ON position, the differential lock solenoid is energized, which shifts the differential lock solenoid valve (200). Oil is routed through the differential lock pressure regulating valve, to the differential lock solenoid valve, and then onto the differential lock clutch piston (198). Oil passing through the differential lock pressure regulating valve is routed to the differential lock solenoid valve and the hydraulic and differential oil cooler (in addition to the return to differential housing) for cooling the brakes. The differential lock pressure regulating valve has oil routed to both ends to regulate oil flow. Oil is routed to the differential lock pressure regulating valve piston (199). Oil pressure combined with spring force overcomes the oil pressure at the opposite end of the valve to help regulate oil flow to the differential housing and hydraulic and differential oil cooler. The oil presses the piston against the disc clutch, compressing it against the housing. Since the discs are splined to the bevel gear and the plates are tanged to the housing, this locks up the bevel pinions and prevents differential action.

For more information on differential lock operation, see [Dif-Lok Differential Operation](#) . (CTM138619.)

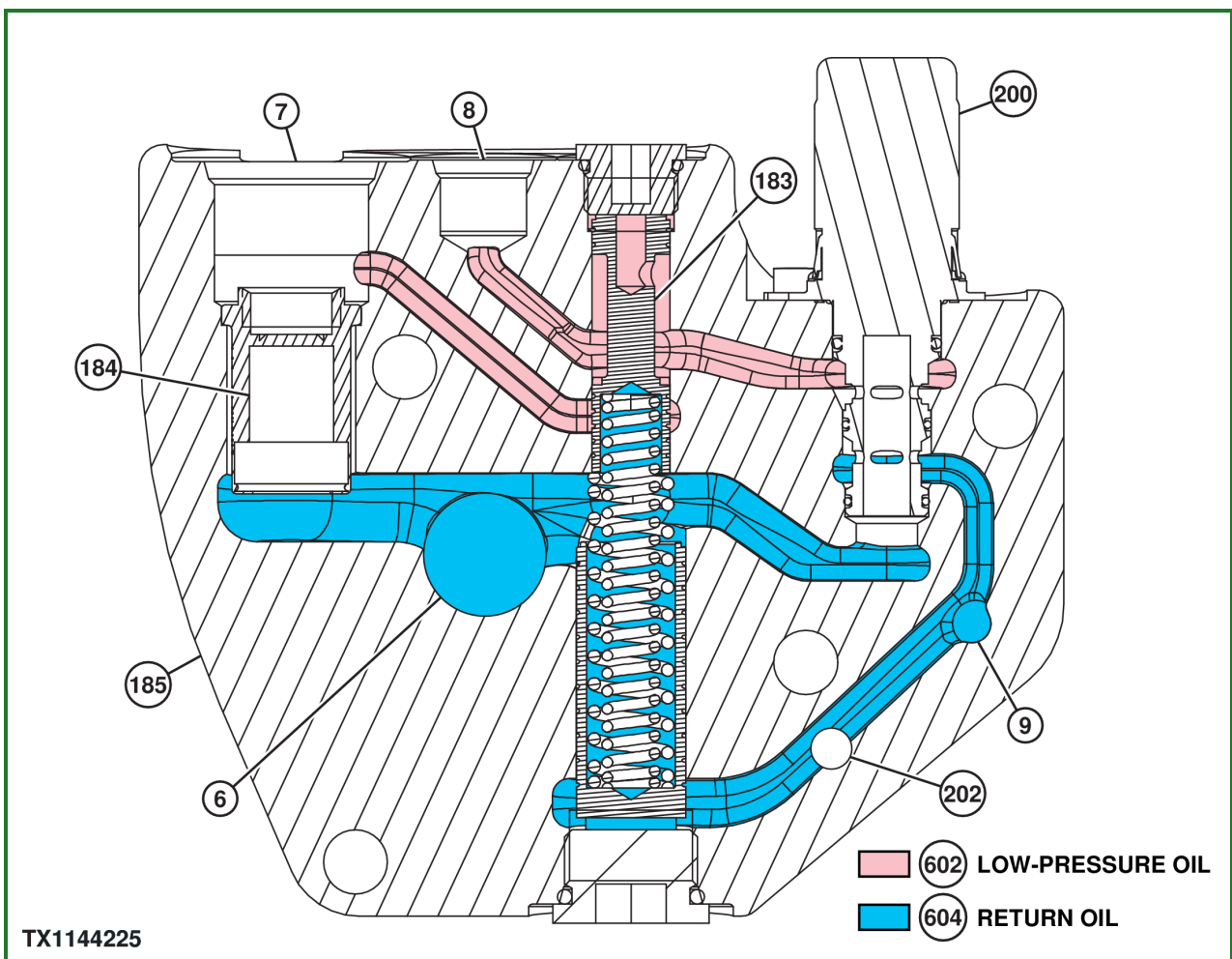

TX1144225-UN: Differential Lock Solenoid Valve

LEGEND: