

Pump 1, Pump 2, and Pilot Pump Line Identification

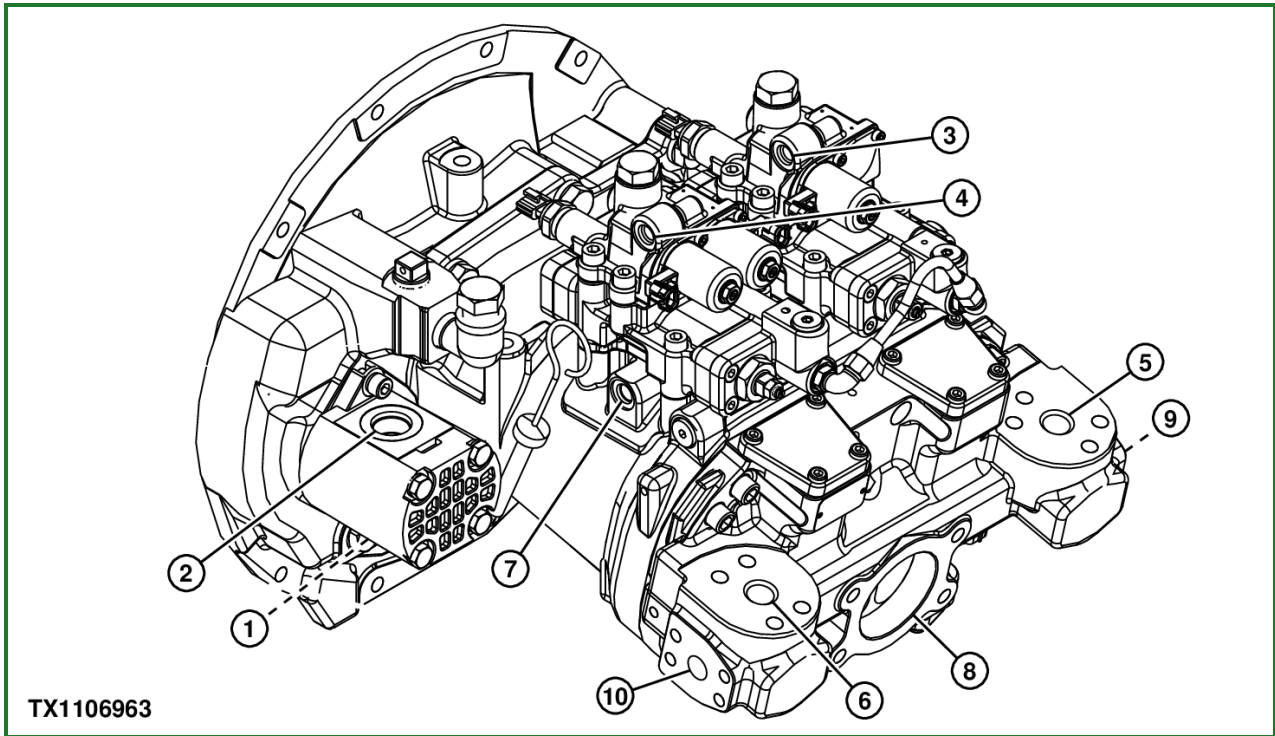

TX1106963

TX1106963-UN: Pump 1, Pump 2, and Pilot Pump Line Identification

LEGEND:

- 1 - Pilot Pump Outlet Port
- 2 - Pilot Pump Inlet Port
- 3 - From Pilot Signal Manifold (port SA)
- 4 - From Pilot Signal Manifold (port SB)
- 5 - Pump 1 Outlet Port
- 6 - Pump 2 Outlet Port
- 7 - From Pilot Pressure Regulating Valve
- 8 - Pumps 1 and 2 Inlet Port
- 9 - Pump 1 Attenuator Port
- 10 - Pump 2 Attenuator Port

Go to [Section_9025:Group_15](#)

JA66566,00016A9-19-20120218

Control Valve Line Identification

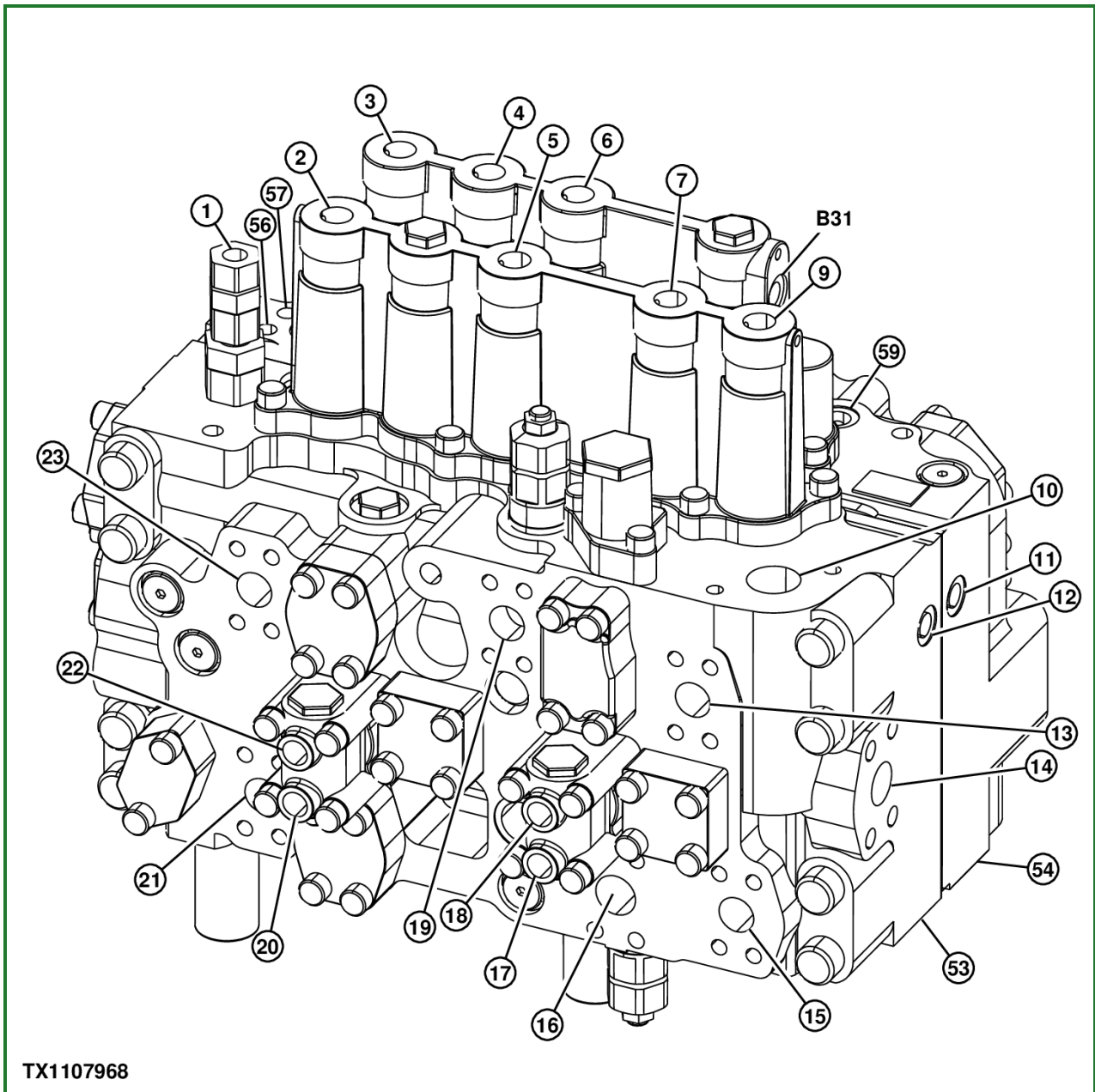

TX1107968

TX1107968-UN: Left Control Valve (5-spool)**LEGEND:**

- 1 - From Power Dig Solenoid Valve (port SG)
- 2 - From Pilot Signal Manifold Left Travel Reverse (port 10)
- 3 - From Pilot Signal Manifold Right Travel Reverse (port 12)
- 4 - From Pilot Signal Manifold Bucket Curl (port 7)
- 5 - To Main Relief Valve Isolation Check Valve (5-spool)
- 6 - From Pilot Signal Manifold Boom Down (port 2)
- 7 - From Pilot Signal Manifold Arm In (port 4)
- 9 - From Pilot Signal Manifold Swing Right (port 6)
- 10 - To Hydraulic Oil Cooler
- 11 - From Boom Lower Meter-In Cut Valve
- 12 - From Boom 2 Spool
- 13 - To Swing Motor Swing Left
- 14 - From Pump 2
- 15 - To Swing Motor Swing Right