

5B-4 Manual Transmission:

- 2) Remove the gearshift fork shafts (3) and gearshift forks (4).

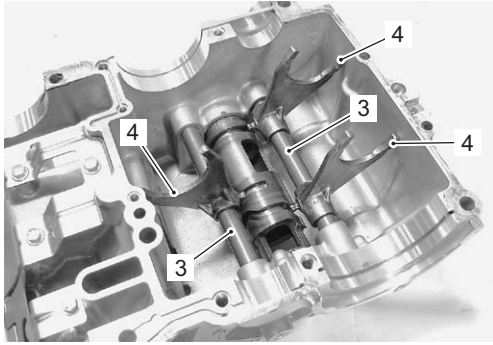

I822H1520007-02

- 3) Remove the gearshift cam bearing (5) and gearshift cam (6).

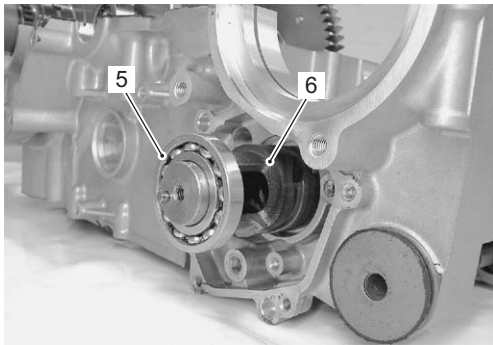

I822H1520008-01

Bearing

Remove the gearshift cam bearing (1) with the special tools.

Special tool

 (A): 09923-74511 (Bearing puller)

 (B): 09930-30104 (Rotor remover slide shaft)

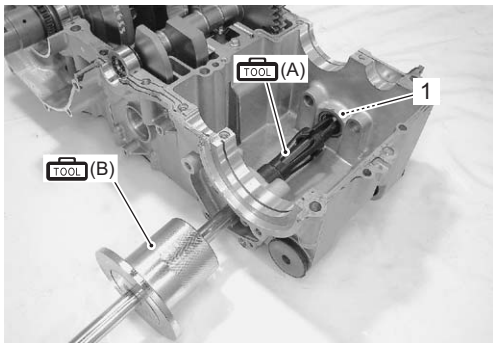

I822H1520009-01

Transmission Installation

B822H15206003

Install the transmission in the reverse order of removal. Pay attention to the following points:

Bearing

CAUTION

Replace the removed bearing with a new one.

Install the bearing (1) with the special tool.

NOTE

The stamped mark side of the gearshift cam bearing (1) faces outside.

Special tool

 (A): 09913-70210 (Bearing installer set)

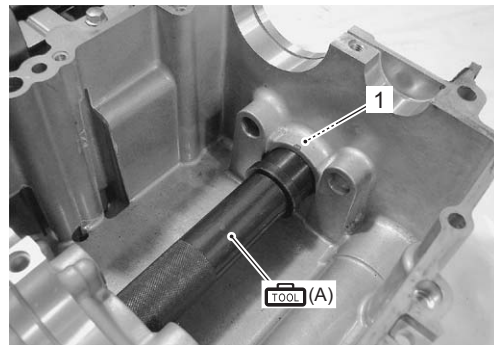

I822H1520010-02

Gearshift Cam / Gearshift Fork

- Install the gearshift cam (1) and bearing (2).

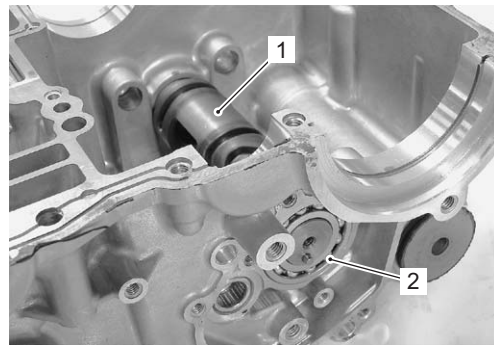

I822H1520011-01

- Install the gearshift fork shafts (3) and gearshift forks (4).

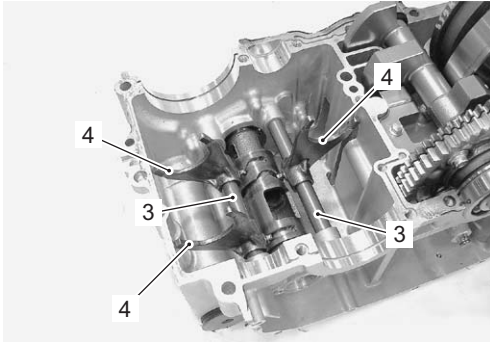

I822H1520012-01

- Tighten the shift fork retainer plug (5) to the specified torque.

⚠ CAUTION

Replace the gasket (6) with a new one.

Tightening torque

Gearshift fork retainer plug (a): 35 N·m (3.5 kgf·m, 25.5 lb-ft)

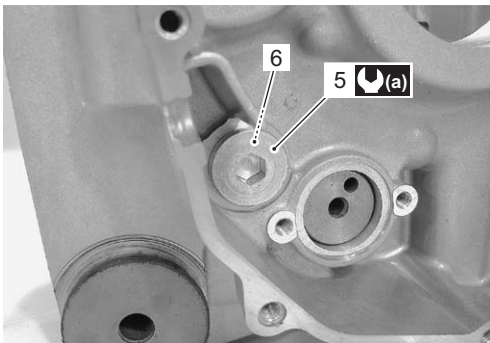

I822H1520013-01

- Apply thread lock to the screws and tighten them.

1303 : Thread lock cement 99000-32030 (THREAD LOCK CEMENT SUPER 1303 or equivalent)

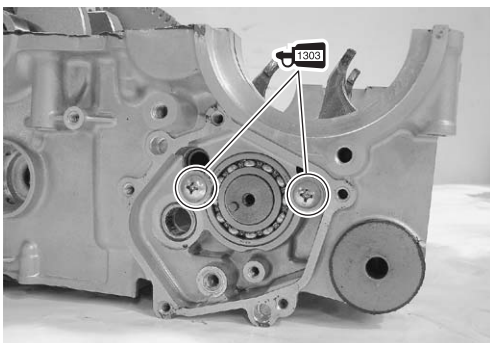

I822H1520014-01

Countershaft Assembly

- Install the bearing pin (1) and C-ring (2).

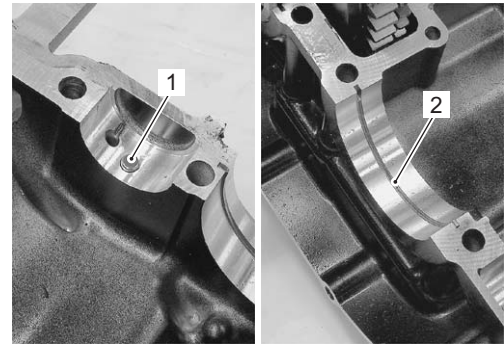

I822H1520015-01

- Install the countershaft on the upper crankcase.

NOTE

Align the C-ring with the groove of the bearing and bearing pin with the indent on the bearing.

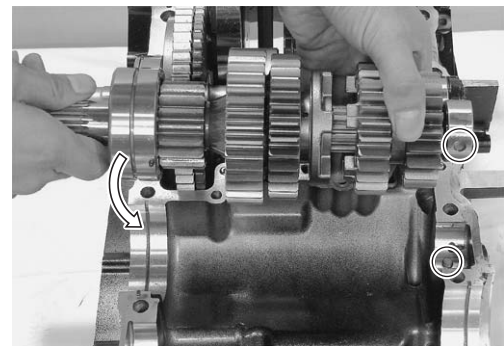

I822H1520016-02

- Turn the bearing to install the bearing dowel pin "A" in the respective position.

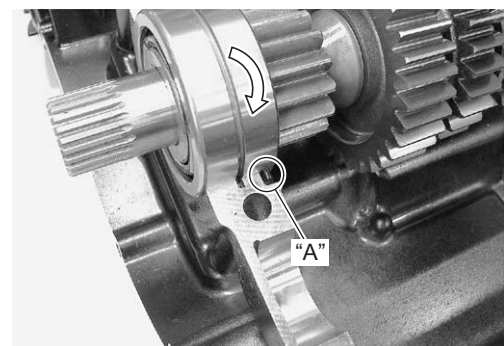

I822H1520017-01