

Check Track Shoe Torque

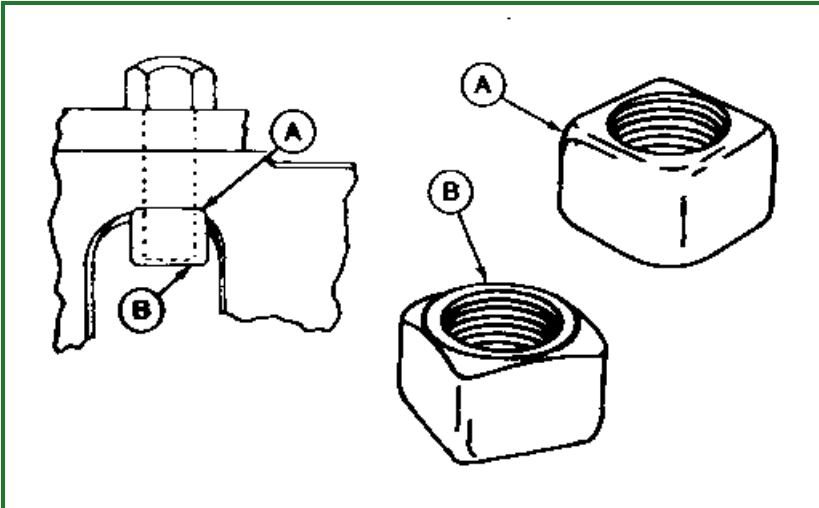

T82862-UN: Track Shoe Torque



T6794AM-UN: Track Shoe Torque

LEGEND:

A - Rounded Edge

B - Chamfered Edge

Track shoe cap screw torque should be periodically checked. If the cap screws do not meet the minimum torque specifications, remove the shoes and clean the mating surfaces of the shoes and links before tightening the cap screws.

If unit is operated with loose track shoes, the cap screw holes in the shoes and links will wear and it may be difficult to keep the track shoes tight. Loose shoes can also cause hardware failure and loss of track shoes.

Install all track shoe nuts with rounded edges (A) against the link and chamfered edges (B) away from the link. Be sure nut is properly positioned in the link so there is full contact area between the nut and the link.

Item	Measurement	Specification
Cap Screw Torque		298 N·m (220 lb-ft) Plus 1/2 turn (180°)

TX,90,FF,294-19-1992/04/09

Unified Inch Bolt and Cap Screw Torque Values

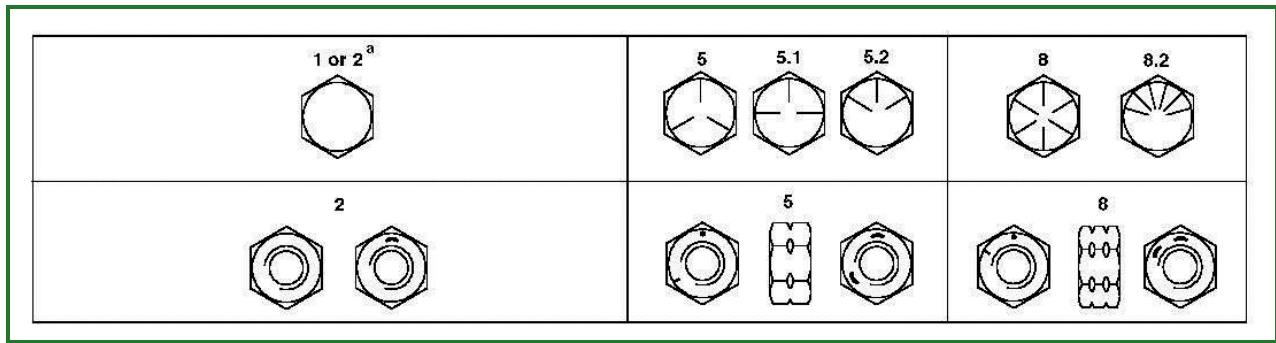

TORQ1A-UN: Top, SAE Grade and Head Markings; Bottom, SAE Grade and Nut Markings

-: Unified Inch Bolt and Cap Screw Torque Values, 1 of 2

Size	Grade 1 (No Mark)		Grade 2 ^a (No Mark)		Grade 5, 5.1 or 5.2		Grade 8 or 8.2	
	Lubricated ^b N·m(lb-ft)	Dry ^c N·m(lb-ft)	Lubricated ^b N·m(lb-ft)	Dry ^c N·m(lb-ft)	Lubricated ^b N·m(lb-ft)	Dry ^c N·m(lb-ft)	Lubricated ^b N·m(lb-ft)	Dry ^c N·m(lb-ft)
1/4	3.8 (2.8)	4.7 (3.5)	6 (4.4)	7.5 (5.5)	9.5 (7)	12 (9)	13.5 (10)	17 (12.5)
5/16	7.7 (5.7)	9.8 (7.2)	12 (9)	15.5 (11.5)	19.5 (14.5)	25 (18.5)	28 (20.5)	35 (26)
3/8	13.5 (10)	17.5 (13)	22 (16)	27.5 (20)	35 (26)	44 (32.5)	49 (36)	63 (46)
7/16	22 (16)	28 (20.5)	35 (26)	44 (32.5)	56 (41)	70 (52)	80 (59)	100 (74)
1/2	34 (25)	42 (31)	53 (39)	67 (49)	85 (63)	110 (80)	120 (88)	155 (115)
9/16	48 (35.5)	60 (45)	76 (56)	95 (70)	125 (92)	155 (115)	175 (130)	220 (165)
5/8	67 (49)	85 (63)	105 (77)	135 (100)	170 (125)	215 (160)	240 (175)	305 (225)
3/4	120 (88)	150 (110)	190 (140)	240 (175)	300 (220)	380 (280)	425 (315)	540 (400)
7/8	190 (140)	240 (175)	190 (140)	240 (175)	490 (360)	615 (455)	690 (510)	870 (640)
1	285 (210)	360 (265)	285 (210)	360 (265)	730 (540)	920 (680)	1030 (760)	1300 (960)
1-1/8	400 (300)	510 (375)	400 (300)	510 (375)	910 (670)	1150 (850)	1450 (1075)	1850 (1350)
1-1/4	570 (420)	725 (535)	570 (420)	725 (535)	1280 (945)	1630 (1200)	2050 (1500)	2600 (1920)
1-3/8	750 (550)	950 (700)	750 (550)	950 (700)	1700 (1250)	2140 (1580)	2700 (2000)	3400 (2500)
1-1/2	990 (730)	1250 (930)	990 (730)	1250 (930)	2250 (1650)	2850 (2100)	3600 (2650)	4550 (3350)

^a Grade 2 applies for hex cap screws (not hex bolts) up to 6 in. (152 mm) long. Grade 1 applies for hex cap screws over 6 in. (152 mm) long, and for all other types of bolts and screws of any length.

^b "Lubricated" means coated with a lubricant such as engine oil, or fasteners with phosphate and oil coatings.

^c "Dry" means plain or zinc plated without any lubrication.