

**IF OK:**

See an authorized John Deere dealer.

**9 Travel Alarm Cancel Switch Circuit Check**

**Action:**

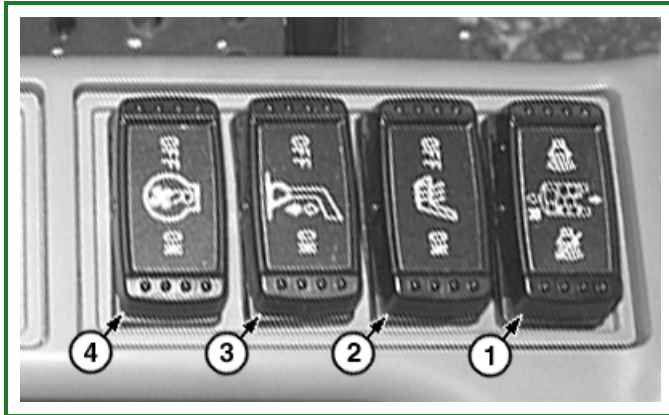

**TX1217119A-UN: Travel Alarm Cancel Switch**

**LEGEND:**

- 1 - Travel Alarm Cancel Switch
- 2 - Seat Heater Switch
- 3 - Boom Mode Switch
- 4 - Reversing Fan Switch

**CAUTION:**

***Avoid possible injury. Machine moves during this check. Make sure area is clear and large enough to operate machine.***

**NOTE:**

*Travel alarm must operate for this check.*

Place pilot shutoff lever in unlocked (DOWN) position.

Push travel pedals or levers and allow travel alarm to operate for a minimum of 12 seconds.

*LISTEN: Does travel alarm sound?*

While continuing travel, push travel alarm cancel switch (1).

*LISTEN: Does travel alarm stop sounding?*

**Record of Actual Results:**

**Result:**

**YES:**

Go to next check.

**NO:**

Check optional and attachment connector 5 A fuse (F5) (marked OPT. 1 ALT). See Replacing Fuses.

(Section 4-1.)

**IF OK:**

See an authorized John Deere dealer.

**10 Hydraulic Oil Tank Pressurization Check**

**Action:**

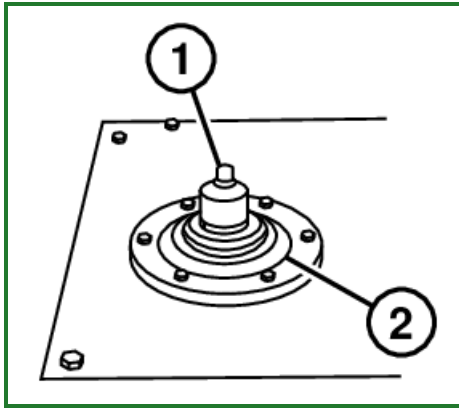

**TX1093766-UN: Hydraulic Oil Tank Cover**

**LEGEND:**

1 - Hydraulic Oil Tank Pressure Release Button

2 - Hydraulic Oil Tank Cover

**IMPORTANT:**

The pressurized hydraulic oil tank creates pressure at the inlet to the hydraulic pumps. If tank cover does not seal, hydraulic pumps could cavitate and be damaged.

Raise boom to full height, then lower boom to ground.

Slowly depress hydraulic oil tank pressure release button (1) on hydraulic oil tank cover (2).

*LISTEN: Is air heard escaping from the pressure release button on hydraulic oil tank cover?*

**Record of Actual Results:**

**Result:**

**YES:**

Go to next check.

**NO:**

Replace hydraulic oil tank cover.

**11 Control Lever Pattern Check—Excavator Pattern**

**Action:**