

Disassembly and Assembly C3.4B Engines for Caterpillar Built Machines

Media Number -UENR4535-07

Publication Date -01/06/2015

Date Updated -28/08/2020

i05825517

Alternator - Install

SMCS - 1405-012

Installation Procedure

1. Ensure that all components are clean and free from wear and damage. If necessary, replace any components that are worn or damaged.
2. If necessary, follow Step 2.a through Step 2.g in order to install alternator bracket (4) and tensioner (11) onto the cylinder block.

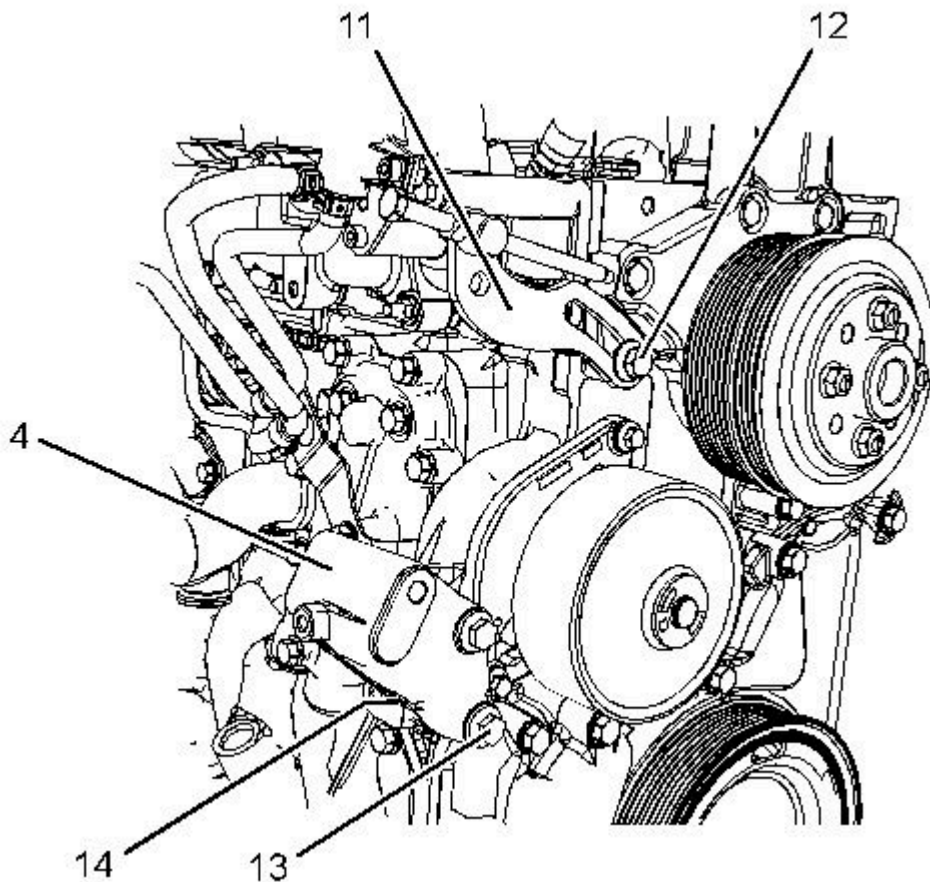

Illustration 1

g03826959

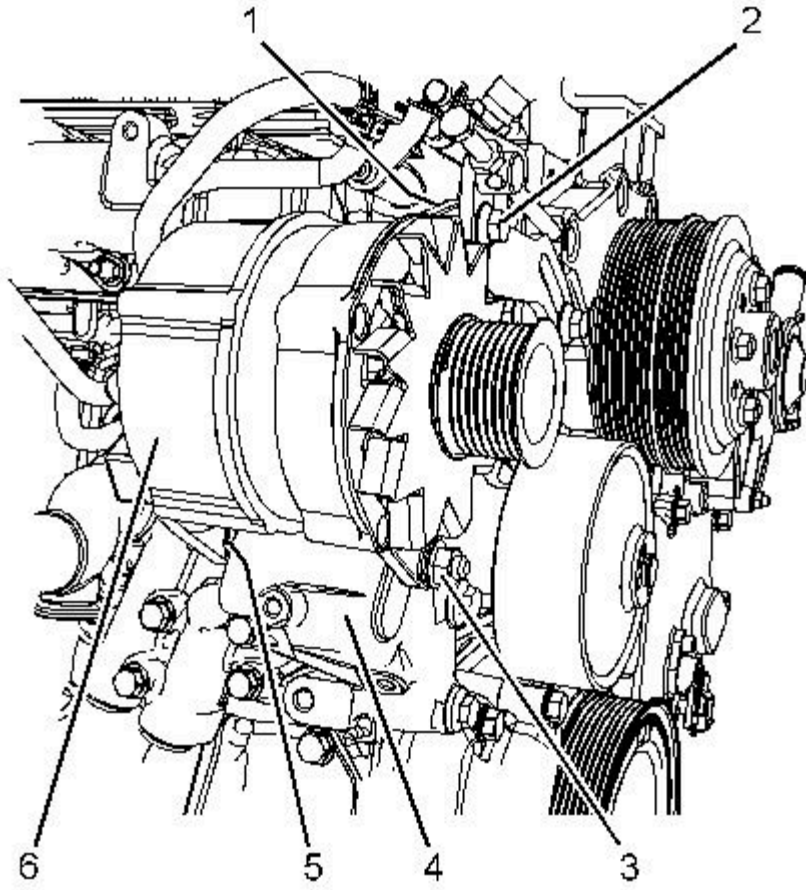

Illustration 2

g02673920

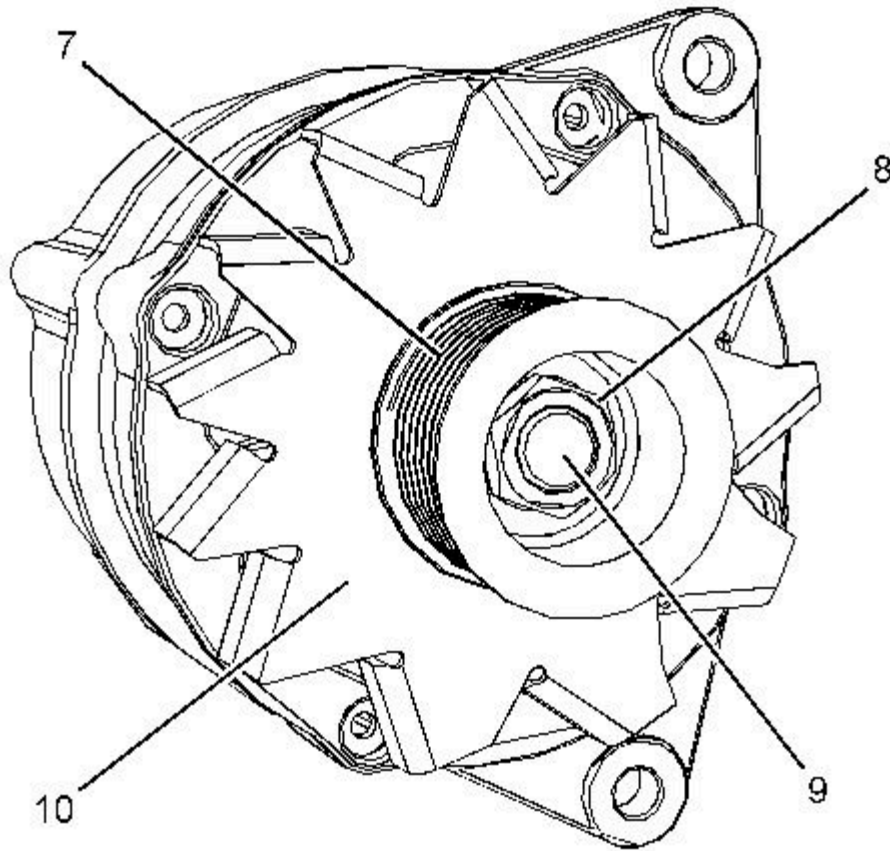

Illustration 3

g02815777

- a. Position bracket (4) onto the cylinder block.
 - b. Install bolts (13) to bracket (4) finger tight.
 - c. If necessary, install bolt (14) to the coolant tube assembly.
 - d. Tighten bolts (13) to a torque of 50 N·m (37 lb ft).
 - e. Tighten bolts (14) to a torque of 25 N·m (221 lb in).
 - f. Position tensioner (11) onto the fan drive assembly.
 - g. Install bolt (12) to tensioner (11) finger tight.
3. If necessary, follow Step 3.a through Step 3.f in order to install pulley (8) to alternator (2).

Note: Either of Tooling (A) may be required in order to carry out the installation of the alternator pulley.

- a. Place alternator (6) in a suitable support.
- b. Ensure that fan (10) is correctly oriented.
- c. Install fan (10) to shaft (9).